

HOLE PATTERN

6 x ϕ 3,15 THRU ALL
TAP FOR M3x0.5 HELICOIL Insert = 2.0 * Dia.

Mounting Plane

$(\phi 110 \pm 0,10)$
 $(\phi 128,9 \pm 0,1)$

$(13,5 \pm 0,10)$

$(27 \pm 0,1)$

$(63 \pm 0,1)$

The information contained in this document is furnished in confidence. Possession hereof in no way constitutes any rights to use, reproduce or disclose the document, in whole or in part, except as authorised by DST Control AB. Copyright DST Control AB as per date of issue hereof. All rights reserved.

UNLESS OTHERWISE SPECIFIED: DIMENSIONS ARE IN MILLIMETERS SURFACE FINISH: TOLERANCES: LINEAR: ± 0.1 ANGULAR: ± 0.1		FINISH:	DEBUR AND BREAK SHARP EDGES	DO NOT SCALE DRAWING	PAPER SIZE A3
DRAWN CHK'D APPV'D MFG Q.A REV.		NAME ASN	DATE 2012-01-24	CLIENT DST CONROL	
STATUS: Preliminary		DST CONTROL ÅKERBOGATAN 10, SE-582 54 LINKÖPING SWEDEN, PHN / FAX +46 13 211080 / 211081 www.dst.se, info@dst.se		PROJECT/PART ICD1152R01 Interface Control Document	
VIEW: DIM	WEIGHT: 386.84	MATERIAL:	FILE/PART NO. ICD1152R01A	CONFIG. CARRIER	REVISION A
			SCALE: 1:2	SHEET 1 OF 3	

RESTING HELIMUNTS

REAR VIEW

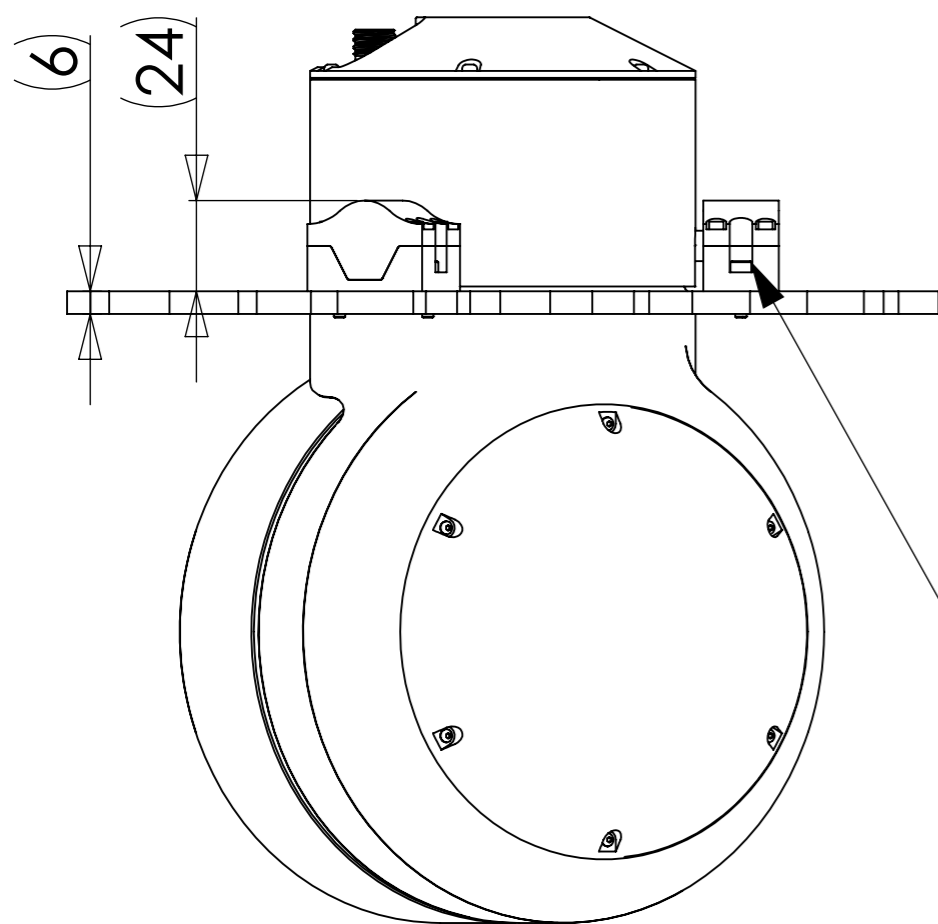

DOWN

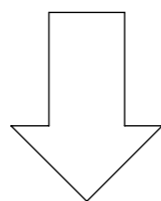

VEHICLE FORWARD
MOTION DIRECTION

ISO VIEW

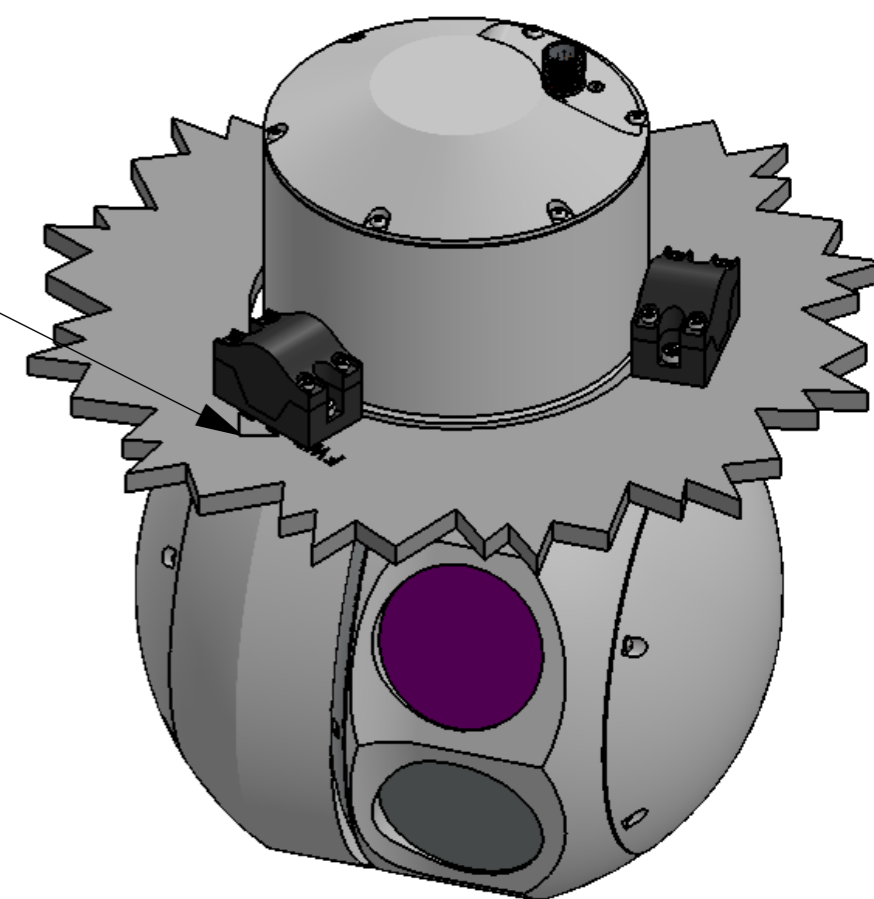

6 SOCKET M3x12 SCREWS
WERE USED FOR THIS
EXAMPLE MOUNTING PLANE
(NOT PART OF THE DELIVERY)

UNLESS OTHERWISE SPECIFIED: DIMENSIONS ARE IN MILLIMETERS SURFACE FINISH: TOLERANCES: LINEAR: ±0.1 ANGULAR: ±0.1		FINISH:	DEBUR AND BREAK SHARP EDGES	DO NOT SCALE DRAWING	PAPER SIZE A3
DRAWN CHK'D APPV'D MFG Q.A REV.		NAME ASN	DATE 2012-01-24	CLIENT DST CONROL	
STATUS: Preliminary		 DST CONTROL ÅKERBOGATAN 10, SE-582 54 LINKÖPING SWEDEN, PHN / FAX +46 13 211080 / 211081 www.dst.se, info@dst.se		PROJECT/PART ICD1152R01 Interface Control Document	
VIEW: DIRR		MATERIAL:	FILE/PART NO. ICD1152R01A	CONFIG. RESTING L170	REVISION A
		WEIGHT: 1138.22	SCALE:1:2	SHEET 2 OF 3	

HANGING HELIMUNTS

REAR VIEW

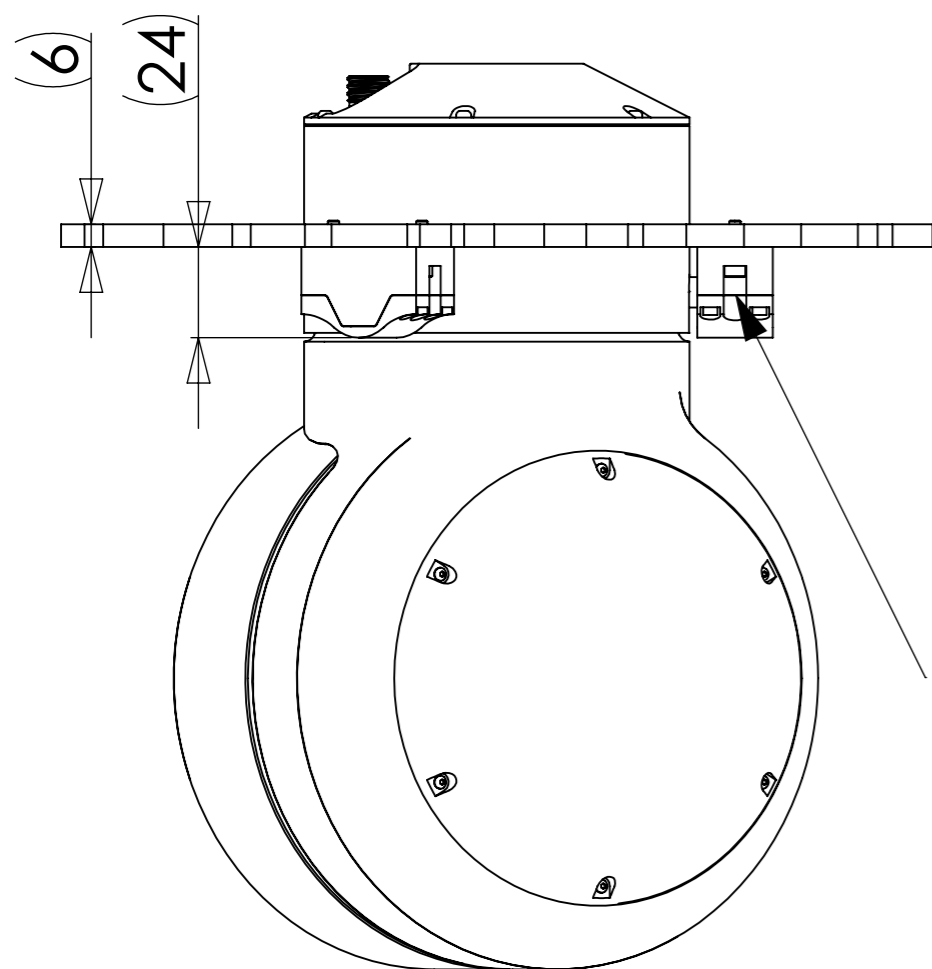

DOWN

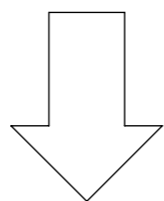

VEHICLE FORWARD
MOTION DIRECTION

6 SOCKET M3x12 SCREWS
WERE USED FOR THIS
EXAMPLE MOUNTING PLANE
(NOT PART OF THE DELIVERY)

ISO VIEW

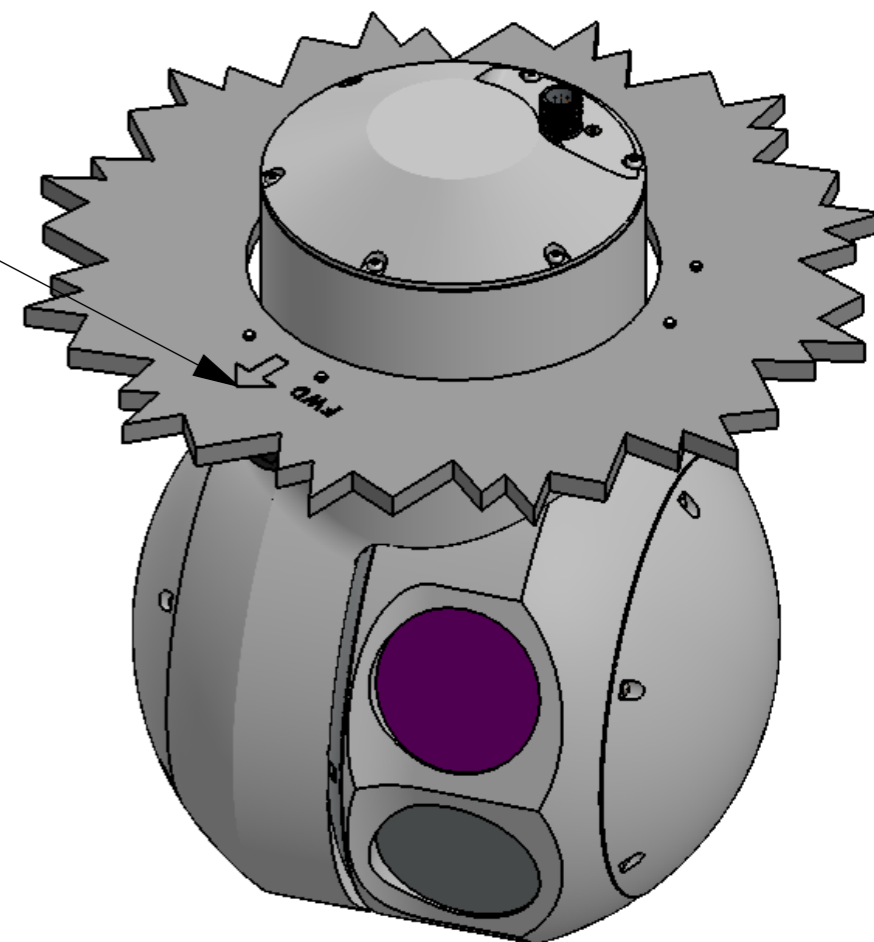

UNLESS OTHERWISE SPECIFIED: DIMENSIONS ARE IN MILLIMETERS SURFACE FINISH: TOLERANCES: LINEAR: ±0.1 ANGULAR: ±0.1		FINISH:	DEBUR AND BREAK SHARP EDGES	DO NOT SCALE DRAWING	PAPER SIZE A3
DRAWN CHK'D APPV'D MFG Q.A REV.		NAME ASN	DATE 2012-01-24	CLIENT DST CONROL	
STATUS: Preliminary		 DST CONTROL ÅKERBOGATAN 10, SE-582 54 LINKÖPING SWEDEN, PHN / FAX +46 13 211080 / 211081 www.dst.se, info@dst.se		PROJECT/PART ICD1152R01 Interface Control Document	
VIEW: DIRH	WEIGHT: 1137.97			FILE/PART NO. ICD1152R01A	CONFIG. HANGING L170A
				SCALE:1:2	SHEET 3 OF 3